

**Interference** may be due to faults and/or deficiencies in either the transmitter or in the receiver or both.

### Receiver Problems

#### Blocking

If the receiver is situated close to a transmitter it may be 'blocked' when the transmitter is operating. The receiver, although tuned to another frequency, becomes overloaded and it will no longer 'hear' the wanted station.

#### Second channel interference

Most receivers are of the superhet type and therefore rely on the mixing process. If two frequencies are mixed there are at least two resultant frequencies: the sum and the difference. This means that for a given Local Oscillator frequency and Intermediate Frequency there will be two frequencies that, if they arrive at the aerial, could be received. The frequency of the unwanted station will be Two Times the IF away from the wanted frequency.

If a domestic radio having an IF of 500KHz, is tuned to 900KHz on the Medium Wave, its Local oscillator will be on 1.4MHz. It could also receive 1.9MHz in the amateur Top band at the same time.

To avoid this, the RF stage of the receiver should be designed to reject the 'second channel'.

#### Local Oscillator Harmonics

If the LO in the receiver generates harmonics these will cause unwanted mixing products and therefore unwanted stations could be received.

EG: A receiver tuned to 1.2MHz has an IF of 460KHz. The LO is 1.66MHz. Its second harmonic (3.32MHz) could mix with a transmission on 3.78KHz and result in the same IF and hence would be heard.

#### Detection

If the receiver or Hi-Fi is not well screened then the RF from a nearby transmitter may enter and be detected by any non-linearity in the audio stages.

#### I. F. Breakthrough

If a receiver has an Intermediate Frequency in an Amateur Band then any transmission on that frequency might be received where ever the receiver is tuned. It is therefore very important that the high gain IF stages of a receiver are well screened.

### CURES

In general, many of the above problems can be reduced by ensuring that the receiver does not get an extremely strong signal from the Amateur Transmitter. In the case of TV and VHF receivers it is important to ensure that the outer of the coax cable does not act as an aerial for the amateur transmissions.

A filter (braid breaker) can be connected in the coax near to the TV or hi-fi. The screen is then no longer connected directly to the receiver. The loss at UHF TV and VHF hi-fi frequencies is very low but HF amateur frequencies are greatly attenuated by the low value coupling capacitors and shunt chokes. This filter should be fitted about one Metre along the cable from the receiver. Signals picked up on the outer of the cable can also be much reduced by winding it several times through a ferrite ring.

Hi-fi equipment usually has two widely spaced loud speakers.

Their leads can act like a very good dipole at amateur frequencies. Pick up can be reduced by altering the length or winding each lead through a ferrite ring.

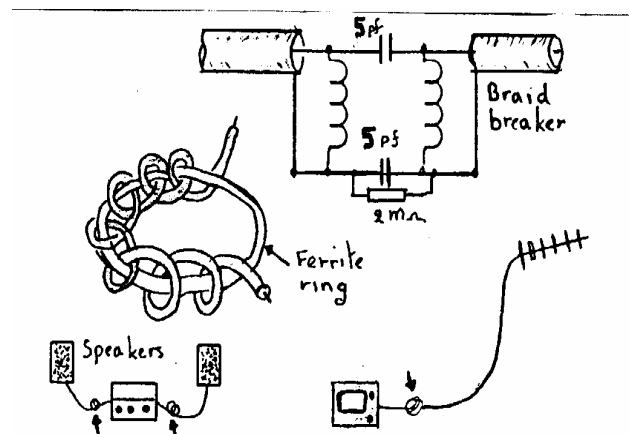

Some receiver problems can only be solved by internal modifications. Diving into your neighbours shiny HI-Fi is not recommended! The problem should, ideally, be referred to the dealer or the manufacturer to improve the selectivity, image rejection, IF and audio breakthrough etc. This recommendation applies even in simple cases: In the audio stage, for example, it may be necessary to add inductance to the base circuit of a transistor. This could be done by simply passing the base connection through a small ferrite bead. However, external circuits can be tried. If a receiver is affected by a particular amateur band an acceptor or a rejector circuit could be connected at the aerial as follows.

Add It in the aerial!

A rejector circuit is a parallel tuned circuit and at its resonant frequency it is a high impedance. Therefore it is connected in series with the aerial wire.

The acceptor is a series tuned circuit and it will have a low impedance at resonance. It is therefore connected across the aerial and earth connection to "short circuit" the unwanted frequency.

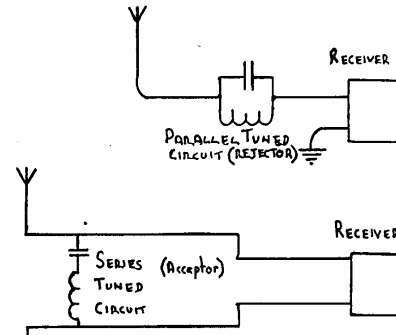

**TRANSMITTER DEFICIENCIES**

A Morse (CW) transmitter, although simple, is capable of producing clean harmonic free transmissions. But precautions must be taken!

When the Morse key is up there is no output. Once the key is pressed there will suddenly be a full output until it is released and the output drops abruptly. These sudden changes (arrowed) will generate clicks that are rich in harmonics. This means that annoying clicks will be heard, not only on the transmitted frequency, but also on its harmonics.

You could be transmitting on 3.505KHz and be interfering with other amateur stations on 7.010, 14.020, 21.030 and 28.04KHz.

Not a desirable state of affairs. Harmonics must be avoided. Some will find themselves outside our bands - beware!

**What can be done?**

The wave shape must be rounded to remove those *harmonic laden* sharp corners. The answer is a key click filter. It comprises

an coil, capacitor and a resistor wired into the Morse key. The coil prevents a sudden build up of current when the key is pressed.

The decay of the current is prolonged by the capacitor and the resistor when the key is released. If this is overdone the build up and the decay will run together and the Morse will be unintelligible.

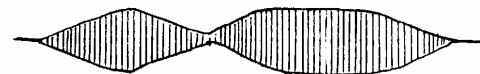
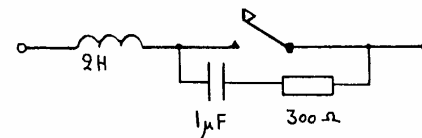
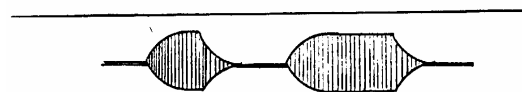
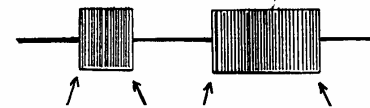
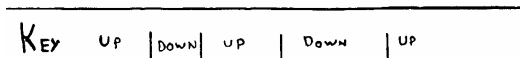

Harmonic Transmission

All waveforms, apart from sinewaves, contain harmonics. It is important to ensure that any harmonics produced by a transmitter are not actually transmitted. In other words the harmonics must not reach the aerial.

Harmonic Reduction

## A Pi-Network

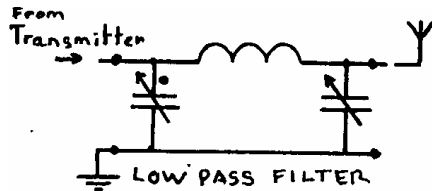

The network is connected between the aerial socket of the transmitter and the aerial wire. It is very effective in reducing harmonics. It is four times better than a simple parallel tuned circuit for reducing the second harmonic and nine times better at the third harmonic.

The frequency multiplier stages of the transmitter should be carefully screened to ensure that no 'unwanted' frequencies escape. Fit a low pass filter in the transmitter output. It should be designed to 'cut off' just above the highest wanted frequency. It is also important to have good earthing and de-couple all the power leads.

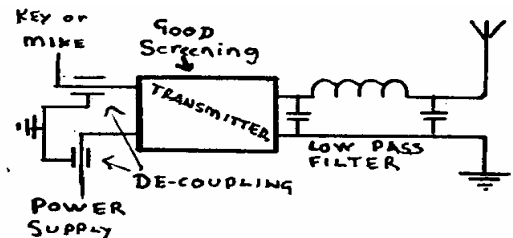
Over Modulation

In an amplitude modulated transmitter, over modulation must be avoided. Ideally, the transmitter should be designed so that over modulation cannot occur. Failing this, an indicator should be fitted to show when 100% modulation is being approached.

Parasitic (or spurious) Oscillations

Certain stages of a transmitter may break out into self oscillation at an apparently random frequency. This may occur: below, above or at the operating frequency of that stage.

Low Frequency..

Radio Frequency amplifiers may burst into oscillation that cannot be sustained. In other words, the oscillation starts - dies away - starts it self again. This is called squegging and it can be caused by poor neutralizing.

Transistors that are used in Radio Frequency amplifiers usually have an, unwanted, high gain at audio frequencies. Neutralization ensures that there is no positive feedback at low frequencies.

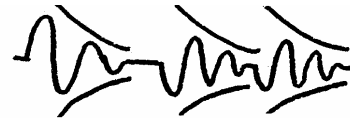
Signal Frequency.

Amplifiers may oscillate at the frequency they are intended to amplify. This can be avoided by ensuring adequate screening between the various circuits. It may also be necessary to change the component layout.

High Frequency.

Actually usually at VHF. This often occurs where some of the components form an "accidental tuned circuit at VHF. If some additional loss can be introduced into the circuit the unwanted oscillations should cease. Valve power amplifiers suffer from this problem and it is usually resolved by adding a low value resistor or a small coil at the grid tag.

It is usually difficult to see which of the components have "unintentionally" formed a tuned circuit at VHF but it must be remembered that even a straight piece of wire has some inductance at VHF.

Chirp

A Morse transmitter should be designed to maintain a constant frequency. If the Variable Frequency Oscillator (VFO) or crystal oscillator is not adequately buffered or the power supply adequately stabilized then the frequency may shift during the "key down" period.

Bandwidth

With a speech transmitter the bandwidth of the transmission is related to the range of audio frequencies present at the microphone and permitted to reach the modulator. In the case of an Amplitude Modulated transmission the transmitted bandwidth will be twice the highest audio modulating frequency.

E.G. "Telephone speech" is from 300 Hz to 3.4 kHz resulting in a signal bandwidth of 6.8 kHz. In order to make the best use of the radio spectrum it is necessary to limit the bandwidth of each signal. In the Amateur Service the highest audio modulating frequency should be 3 kHz.

The microphone amplifier is designed to attenuate all frequencies above 3 kHz.

A Single Sideband transmitter would have a bandwidth of 2.7 kHz (3-0.3). To be even more bandwidth efficient the speech 2.8 is usually limited to 2.~kHz giving a bandwidth of only 2.1kHz.

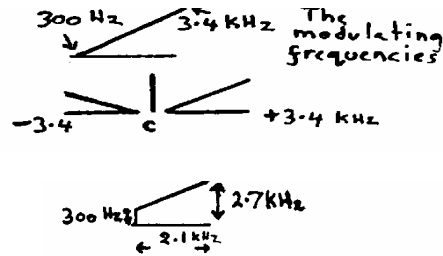

THE LOW PASS FILTER a bit more information

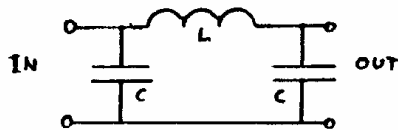

This simple 4MHz Low Pass Filter will not suddenly cut off at its nominal frequency. The output will drop off and (in this example) be very low

- at 5 or 5.5 MHz.

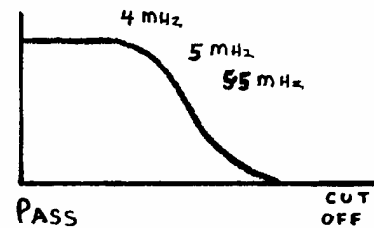

This filter could be used in an 80 Metre (3.5 -3.8 MHz) transmitter.

The Amateur band itself would be unaffected, but its second Harmonic (7-7.6MHz) and above, would be much reduced.

Multiband transmitter - its low pass filter. Ideally a switched low pass filter should form the output of a transmitter that can operate on several bands. For each band it should be designed to pass the actual transmitter frequency but not its harmonics.

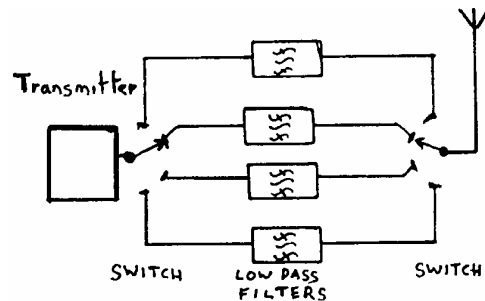

AVOIDING THE UNWANTED

A transmitter is designed to transmit radio frequencies but it is important to ensure that only the wanted one is radiated. The transmitter will, however, generate many unwanted frequencies. Great care is necessary in the electronic design and the physical construction. Remember that each mixing process will produce many frequencies only one of which will be the wanted one. All the unwanted products must be attenuated to ensure that they do not appear at the output to the aerial. Also, the case must be made so that unwanted frequencies do not leak out.

Beware: the aerial is not the only lead connected to the transmitter. Unless the mains (or power supply lead) is adequately decoupled to RF it may well allow unwanted frequencies to reach the outside world.

Is your SWR bridge guilty?

It is also possible that unwanted frequencies are being produced by non-linear devices outside the transmitter. For example the diodes in the SWR meter will produce harmonics of the transmitted frequency. Therefore if an SWR meter is to be left in the aerial lead during transmissions it should be followed by a low pass filter.

Suggested Station Layout

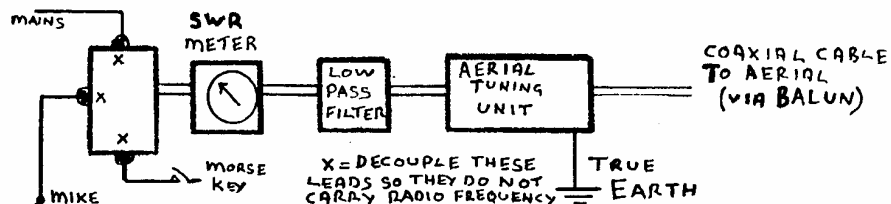

11/1 This is the symbol for:



- a) Variable Capacitance Diode    b) Zener Diode    c) Point Contact Diode    d) Tunnel Diode

11/2 The main advantage of a high intermediate frequency is to:

- a) give a *narrow* pass-band    b) give adjacent signal rejection  
c) reduce Image Interference    d) reduce tracking problems

11/3 Harmonic selecting frequency multipliers NOT used in SSB transmitters because the:

- a) deviation would be increased in proportion to the multiplication.  
b) modulation depth is increased in proportion to the multiplication.  
c) the bandwidth is decreased in proportion to the multiplication.  
d) sideband contains speech which cannot be multiplied.

11/4 In between which of the following stages would you expect PI-NETWORK filter to be used as a matching device?

- a) The driver and the P.A.    b) The oscillator and multiplier  
c) Mike and audio amplifier    d) P.A. and aerial matching cct.

11/5 Which component in an SWL meter will generate harmonics of your transmitted signal?

- a) Moving coil meter    b) The diodes    c) The decoupling capacitors    d) The carbon resistors.

11/6 The advantage of coaxial cable, for aerial feeder, is that it :-

- a) is relatively cheap    b) has less loss than other types    c) easy to install    d) is easier to check for high SWR

11/7 A folded dipole is used in a Yagi aerial because it:

- a) reduces the aerial impedance    b) increases aerial impedance  
c) lowers the angle of radiation    d) reduces its length

11/8 The most active bands for skip type<sub>1</sub> long distance communication are:

- a) 14 and 21 MHz bands    b) 1.8 and 3.5 MHz bands    c) 70 and 144 MHz bands    d) 432 and 144 MHz bands

11/9 Which part of a receiver is most likely to cause interference to other nearby receivers?

- a) Radio Frequency amplifier    b) Local Oscillator    c) Audio Driver stage    d) Detector

11/10 If two frequencies are connected to each of the following devices which could create the most interference by giving rise to mixing products?

- a) Unbalanced resistive network    b) A capacitive coupler    c) An inductive transformer    d) A transistor amplifier

11/11 Which class of amplifier operation is likely to generate most harmonics when used in a transmitter Power Amplifier stage?

- a) Class A    b) Class B    c) Class AB    d) Class C

11/12 When using an end fed aerial a good earth is necessary. The earth terminal of the aerial tuning unit should therefore be connected to:

- a) mains earth    b) ground earth    c) ground earth & mains earth    d) gas pipe or water pipe